



**PATENTED RIVETING MACHINE  
YOSHIKAWA IRON WORKS**

# US-150

Handling Manual





- Be sure to read this manual carefully before using the product and use it correctly. Improper operation may cause accidents, shorten the life of the product, and degrade its performance.
- Keep this manual in a safe place so that it can be used at any time.









## "Safety Precautions"

The precautions shown here are intended to ensure that you use the product correctly and to prevent injury or damage to you or others. In addition, in order to clarify the magnitude and degree of urgency of danger and damage, precautions should be classified as "DANGER," "WARNING," and "CAUTION." Be sure to follow all of these important safety instructions.

	<b>DANGER</b> Failure to observe these instructions results in an imminent likelihood of death or serious personal injury.
	<b>WARNING</b> Failure to observe these instructions results in the possibility of death or serious personal injury.
	<b>CAUTION</b> Failure to observe these instructions results in the possibility of personal injury or material damage.

## About the symbols

The symbols shown below are used to classify and explain the types of items to be observed. Please read the contents carefully.

	The  symbol indicates a "DANGER," "WARNING," or "CAUTION" .
	The  symbol indicates a "prohibited" action that must not be performed.
	The  symbol indicates a "compulsory" action that must be performed.



**DANGER**

	<p>◆ Be sure to conduct a risk assessment under actual usage conditions of the product after it is delivered, it is moved to a different place, new workers begin to use it, there is a change in products being made, there is a change in the surroundings or layout, etc. Otherwise, fires, electric shocks, death or injury, and equipment damage may result.</p>
	<p>◆ Do not put your hands or fingers under the head of the machine as you may be seriously injured. Be very careful while operating the machine.</p>
	<p>◆ Do not open the control box door. There is a risk of electric shock. If you must open the control box door, first turn off the power and unplug the power cord, before opening the door.</p>



**WARNING**

	<p>◆ Secure the machine housing to the floor or to a workbench. If it is not truly secured, the machine may accidentally fall over and injure someone.          We cannot guarantee against product damage or personal injury in the event of an accident.</p>
	<p>◆ Do not use any power supply or voltage other than that which is specified.          Using a different power supply may cause product failure or start a fire.</p>
	<p>◆ Do not damage the wiring. If a damaged wire causes a short circuit, the cord will melt and may start a fire.</p>
	<p>◆ Do not splash water on the product.          Doing so may damage the product, give someone an electric shock or start a fire.</p>
	<p>◆ Never attempt to disassemble or repair this product unless you are a repair technician. Doing so may start a fire or cause a malfunction resulting in personal injury. In case the machine needs repair or fails to work correctly, please contact our sales office nearest to you.</p>
	<p>◆ Do not touch the switches with wet hands.          Doing so may give you an electric shock or cause a malfunction.</p>



## CAUTION

	<ul style="list-style-type: none"><li>◆ Turn off the power before replacing the head, the insert, or a jig. Doing so while operating the machine may result in injury due to incorrect operation.</li></ul>
	<ul style="list-style-type: none"><li>◆ After installing or relocating the machine, be sure to remove the head from the machine and check the direction of the motor's rotation when performing a test run. If it rotates in the wrong direction, the head may come off and cause damage or a personal injury.</li></ul>
	<ul style="list-style-type: none"><li>◆ Do not put your fingers or other objects into the rotating parts during operation. Doing so may cause a personal injury or a machine malfunction.</li></ul>
	<ul style="list-style-type: none"><li>◆ Since the source pressure of the riveter is already set for each model, do not change it without knowing what you are doing. If you use the machine at a pressure above the existing setting, it may damage the machine or cause it to malfunction.</li></ul>
	<ul style="list-style-type: none"><li>◆ Be sure to connect all wires and terminals securely. If you don't, it may result in a poor contact, damage the machine or cause it to malfunction.</li></ul>
	<ul style="list-style-type: none"><li>◆ Please use only genuine items purchased from us, for use as consumables and replacement parts. If you don't, it may damage the machine or cause it to malfunction. When disposing of the machine and/or any parts, treat them as industrial waste.</li></ul>
	<ul style="list-style-type: none"><li>◆ In the event of an accident or machine damage or failure, immediately turn off the power and stop operation. If repair is required, please contact our nearest sales office.</li></ul>
	<ul style="list-style-type: none"><li>◆ If the power is turned off for a long time, the cylinder will drop. If there is any interference (contact) with jigs, or other items nearby, it may damage the machine.</li></ul>
	<ul style="list-style-type: none"><li>◆ Do not allow any mechanical shocks (impacts) when installing the machine. They may cause a machine failure.</li></ul>

## Disclaimer

### “Exclusions from warranty coverage”

In the unlikely event that a problem occurs with this product, we will deal with it based on the following exclusions and disclaimer.

- Defects caused by not following the precautions described in this instruction manual.
- Defects due to design and installation that violate the descriptions in this operation manual
- Defects due to any use other than the intended purpose described in this operation manual
- Defects caused by the installation and handling of the machine due to user instructions given to the designers and installers, that are not part of the standard specifications, are not covered.
- Modified machine specifications or performance after delivery and any defects caused by that.
- Defects caused by use, storage, transportation, etc., outside of the range of environmental conditions normally expected at the time of development, manufacturing, and sales
- Defects caused by force majeure (natural disasters, landslides, ground subsidence, fires, explosions, riots, etc.)
- If any defect is not reported promptly after being discovered

### "Precautions for safe use"

#### 1. Operating conditions and ambient environment

- Please check the operating conditions where the machine will be used and its environment, including: the operating hours and machine settings, the resulting finished products, the waste generated during production, the temperature, humidity, altitude, and atmosphere, such as dust or gas in air at the place where the machine will be used
- If the customer moves or exports the product overseas, they should check the power supply, installation environment, surrounding environment, etc. of the country or region where it will be used.

#### 2. Necessity to confirm the place of use (regulations of municipalities, etc.)

- Check the local ordinances where the machine will actually be used.
- If the customer moves or exports the product overseas, they should check the laws, regulations, and ordinances of the country or region where the product will be used.

#### 3. Necessity for worker education

- The machine may only be installed by a trained person, such as a professional contractor or a specialized person.
- In the case of special work stipulated by laws and ordinances, only a qualified person, or a person who has undergone the necessary training, should perform the work.
- Only persons who have had safety training should perform any work using the machine.
- Work using the machine should only be performed by trained personnel.
- Maintenance work must be performed by engineers or technicians with the necessary mechanical and electrical expertise.
- In the case of special work stipulated by laws and ordinances, only a qualified person, or a person who has undergone the necessary training, should perform the work.

#### 4. Necessity of risk assessment

- Perform a risk assessment under the actual conditions of use, such as the environment, location, and qualifications of workers at the place where the machine will actually be used.
  - Various safety devices are available as options, so please contact our sales office.
-



---

## "Precautions for safe use"

### 5. Need for primary power protection

- If power supply circuit protection is required as the result of the risk assessment, take the appropriate protective measures.
- Various protective devices are available as options, so please contact our sales office.
- If electrical noise countermeasures are required for the machine power supply line, etc., please contact our sales office.

### 6. The need to identify the person involved, including repair work

- To use this machine, we recommend that the customer clarify the work details and scope of responsibility as shown below. Please check each item before starting operation.

① Transportation and Installation: Transporter, machine transportation, and installation manager

② Electrical work/wiring: Electric worker, electric engineer

③ Production: Workers who have had safety training and received explanations of working conditions

④ Setup changes, new model addition: Only performed by workers and managers who have had safety training and received explanations of the working conditions,

⑤ Maintenance and inspection: Mechanical and electrical maintenance engineers

⑥ Repair (mechanical system): Mechanical maintenance engineer (limited to the scope specified in the manual)

⑦ Repair (electrical system): Electrical maintenance engineer (limited to the scope specified in the manual)

⑧ Other repairs: Manufacturer

⑨ Disposal: Disposal contractor, person in charge of the disposal business

\* If ①, ②, ⑤, ⑥, or ⑦ above are special work specified by law, the work should only be done by a qualified person or a person who has received the necessary training.

### 7. About disposal

- When disposing of the machine, check the requirements of the municipality where it will be disposed.
- When disposing of the product overseas, check the laws, rules and regulations of the country or region where the product will be disposed.

**In the event of a failure or malfunction, please contact our sales office.**

---

## CONTENTS

■ <u>Foreword</u>	1
■ <u>Specifications, US-150</u>	2
■ <u>Specifications, US-150E</u>	3
<u>1. Machine installation and environment</u>	
1-1 <u>Mounting and installation</u>	4
1-2 <u>Environment</u>	4
■ <u>Accessories</u>	5
■ <u>Standard head and insert (optional)</u>	6
■ <u>Jigs, tools and operation switches (optional)</u>	7
■ <u>Name of each part</u>	8
<u>2. Preparation for operation</u>	
2-1 <u>Workflow</u>	9
2-2 <u>Connecting a power supply</u>	10
2-3 <u>Turning the operation preparation step on and off</u>	
2-4 <u>How to install the riveting tools</u>	11
<u>3. Making adjustments</u>	
3-1 <u>Stroke adjustment</u>	12-13
3-2 <u>Adjusting the riveting pressure</u>	14
3-3 <u>Speed adjustment</u>	15
3-4 <u>Work timer adjustment</u>	15
■ <u>Head maintenance tasks</u>	16
■ <u>Machine maintenance tasks</u>	17
■ <u>Daily checks</u>	18
■ <u>Troubleshooting page</u>	19
■ <u>Cylinder cross section</u>	20
■ <u>Hydraulic circuit diagram</u>	21
■ <u>Thrust vs operating pressure diagram</u>	22

---

---

---





## ■ Foreword

Thank you for choosing Yoshikawa's "US-150" riveting machine

This is an excellent machine that is the result of many years of our experience and research as a professional manufacturer of riveting machines.

This manual describes how to handle it and points to take note of when using the US-150. Improper handling may cause accidents or malfunctions. Therefore, please make sure to read this manual thoroughly before using the riveter and then use the machine as directed.

Please make sure that this manual is handed to and read by anyone who will be using the riveter. Keep the manual handy for easy reference by anyone operating the riveter.

## Method of operation

This riveting system has a head with a spindle that rotates at the tip of a special hydraulic cylinder. There is also an insert that can be rotated at an angle with respect to the rotation axis of the head. The insert itself can also rotate freely. So, even if the head continues rotating, the insert can stop regardless of the rotation of the head. See Fig.1b.

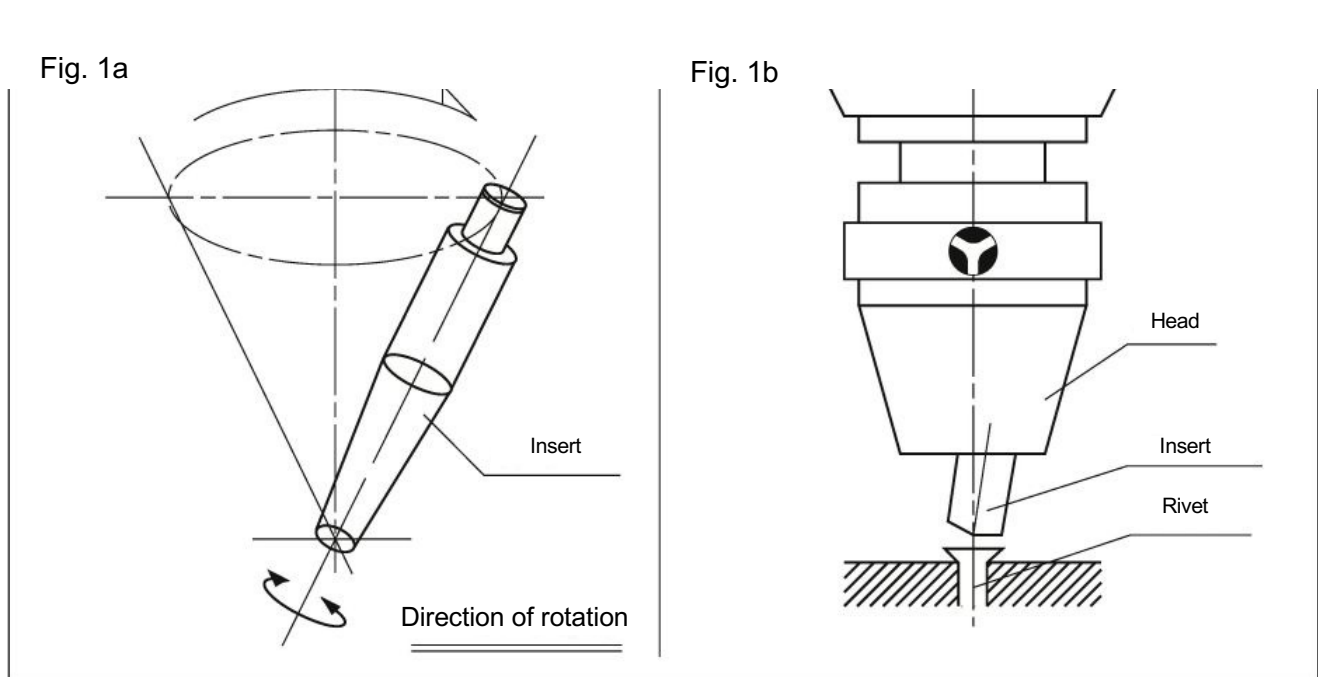

Normally, the insert rotates together with the head of the rivet machine. Then, when the insert touches the top edge of a rivet, the insert itself stops rotating and instead it moves around the top surface of the rivet as described next. See Fig. 1a.

The tip of the insert first contacts a rivet at a point on the outer edge of the top surface of the rivet. Then, its movement describes a circular line as the cylinder descends. Finally, it moves with a length equal to the radius of the rivet head. Based on the principle that the contacting point of the insert tip on the rivet head will move from the edge of the head to the center, the surface can be shaped as desired. The surface shape formed can be flat, cone, pan-shaped, etc., depending on the shape of this contact line.

The deformation of the rivet follows the movement of the contact line between the rivet and the insert, and the rivet head shape will change in microscopic amounts, while simultaneously completing the riveting operation .



## ■ Specifications

US-150 dimensions      Download: <https://www.riveting-mcn.co.jp/>

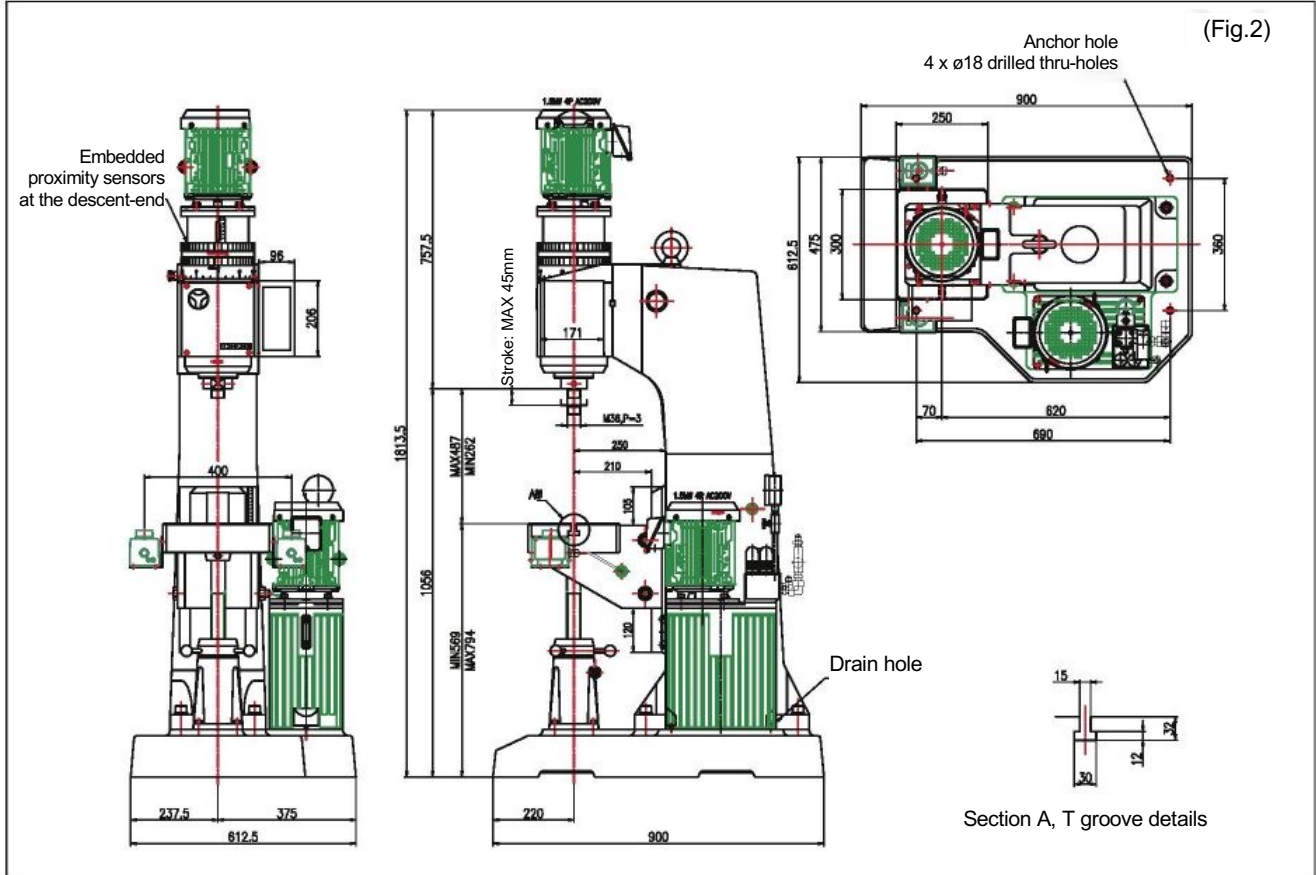

### • Specifications

	Mild steel rivet $d=6\sim 15\text{mm}$ $d=0.24\sim 0.6\text{inch}$		3 $\phi$ AC200V 50/60Hz 4P 1.5kW
	Crimping ability		Power supply
	Stroke S Pressing force P $S=0\sim 45\text{mm}$ $P=\text{MAX}24,500\text{N (2,500kgf)}$		Paint
	Working time timer $t=0.2\sim 9.99\text{sec}$		Tank capacity 12L (turbine oil No 32, or equivalent)
	Spindle motor 3 $\phi$ AC200V 50/60Hz 4P 1.5kW		Weight 680kg
			Housing color JPMA (Japan Paint Manufacturers Association) No.N-55 Hydraulic unit, motor, and control box JPMA No.N-10 (Matte)

The design, dimensions, etc. are subject to change without notice.

■ Specifications

US-150E outline dimensions

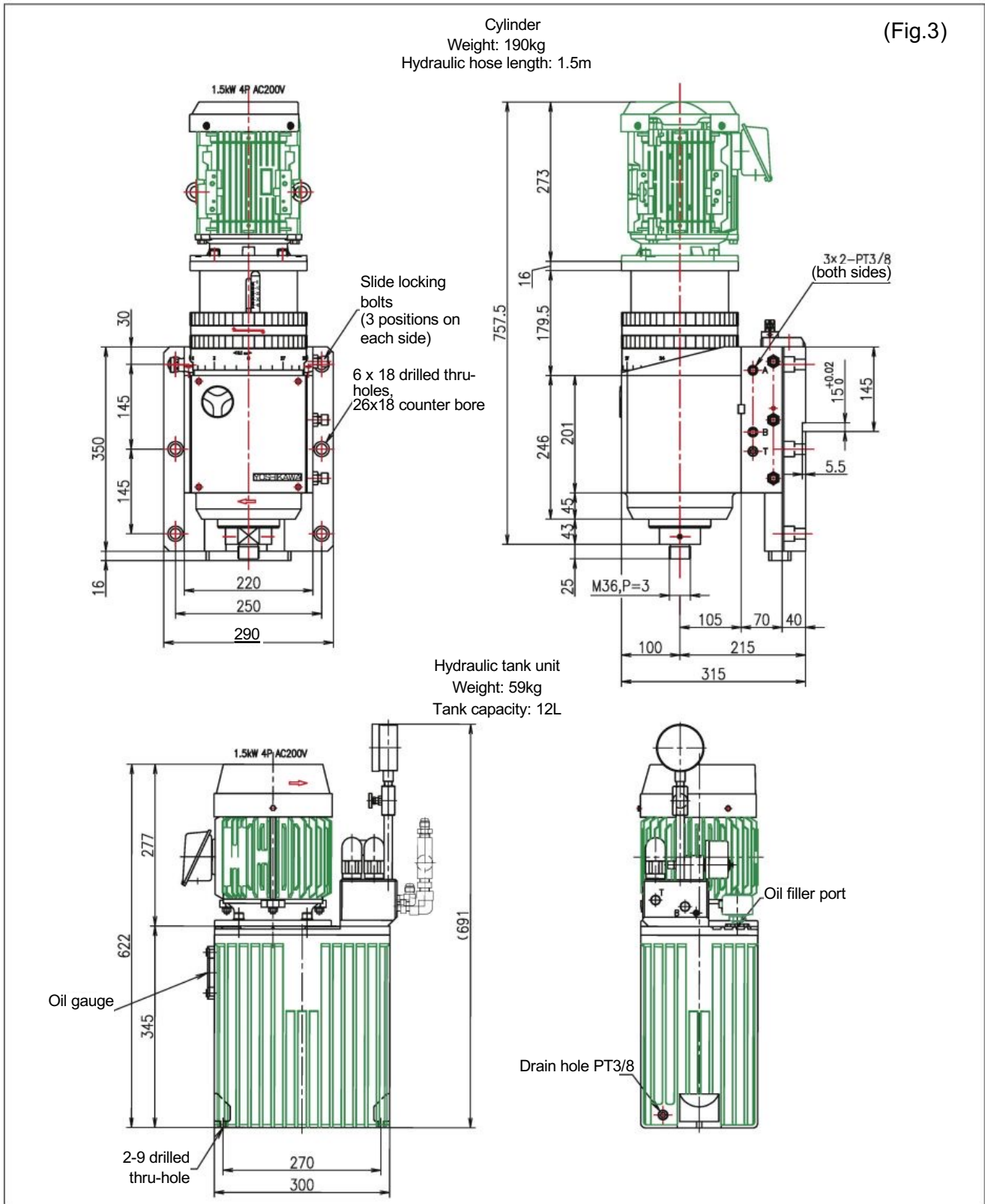

◆The design, dimensions, etc. are subject to change without notice.



# 1. Machine installation and environment

Fig.4.1

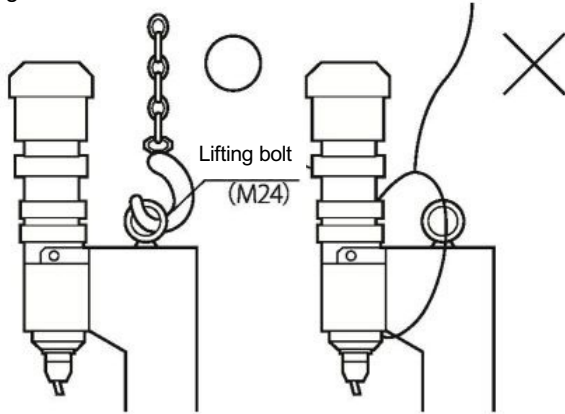

Fig.4.1

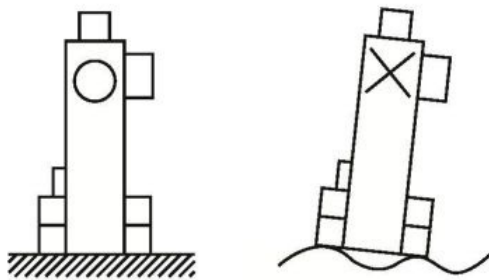

Fig.4.3

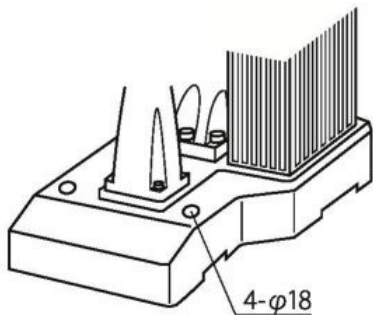
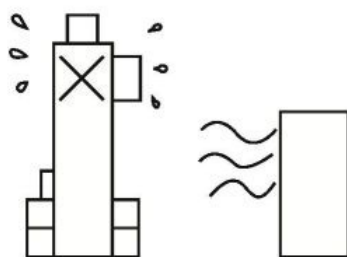

Fig.5



## 1-1 Mounting and installation

### 1) Transport and movement (Fig.4.1)

When transporting or moving the machine, use the lifting bolts (M24) on the machine column. Lift the machine using equipment with a lifting capacity of 1t, or more.  
US-150 = 680kg

**⚠ DANGER!**

- Do not lift the machine using any positions other than those shown.
- If you do not have the necessary equipment and/or facility for transporting or moving the machine, please hire a specialized contractor, or consult us. Never do it the "easy" way.

### 2) Installation (Fig.4.2)

#### a) Preparation

Installing and securing the machine correctly requires a flat floor surface. Therefore, prepare an installation space in advance, or prepare a stand designed for the purpose.

#### b) Securing (Fig.4.3)

Secure the machine using anchor bolts or the like put through the two anchor holes (ø18) at the bottom of the machine.

**⚠ DANGER!**

- If the installation location is uneven or unstable, the machine may topple over due to an earthquake, or other such event.

## 1-2 Environment (Fig.5)

When using or storing this machine, please make sure the following environmental conditions are met.

Environmental items	Environmental conditions
Ambient temperature	0°C to +50°C
Ambient humidity	90% RH or below (non-condensing)
Storage temperature	-10°~+50°C
Storage humidity	90% RH or below (non-condensing)
Ambient atmosphere	Indoors (not exposed to direct sunlight) There should be no corrosive or flammable gas present, and very little oil mist or dust in the environment.

**⚠ DANGER!**

- Never install the machine near an open fire. Doing so may cause a fire in the machine.

## ■ Accessories

The following tools and equipment are included with this machine. Please check that they were supplied.

- If anything is missing, please contact our sales office nearest you.

### Accessories for the US-150 and 150E

- Items stored in the packing case

- One copy of the handling manual (this book)
- One single-ended wrench 19
- One single-ended wrench 30 (not included with the E-type machine)
- One set of Allen wrenches 3, 6, and 8mm
- One spindle handle,  $\varnothing 12 \times 248 \text{mm}$
- One tool case
- Two T-shaped M12 nut (not included with the 70-E type machine)
- One ratcheting socket driver 371B (70E-type machine only)

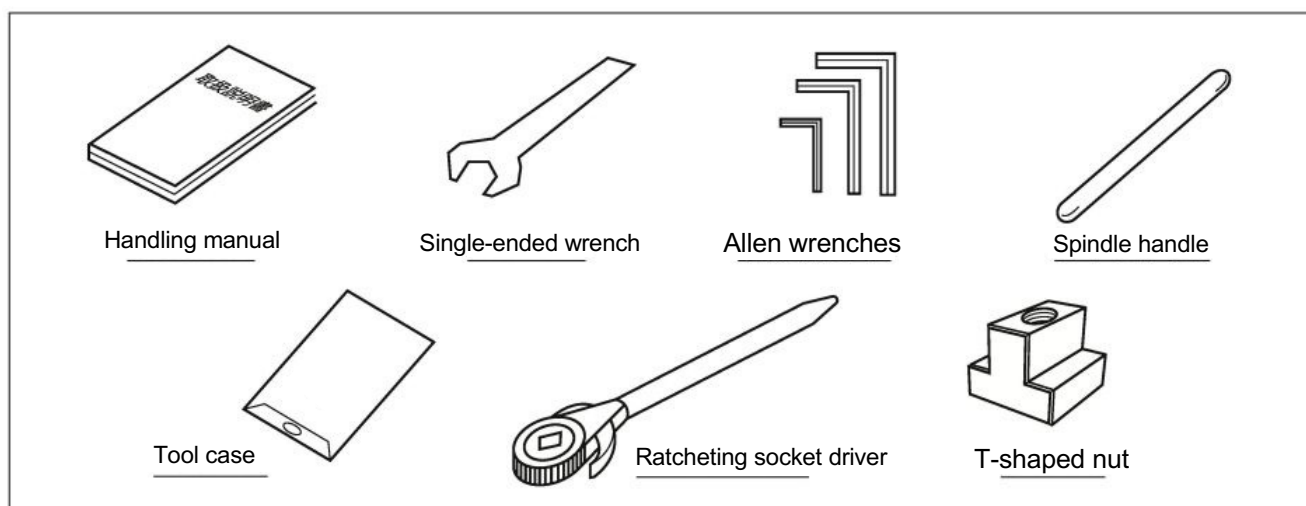

- Items already installed on the machine

- Double push-button start switches (with mounting bracket)
- One power cord (with ground plug, 3P 20A) 5m

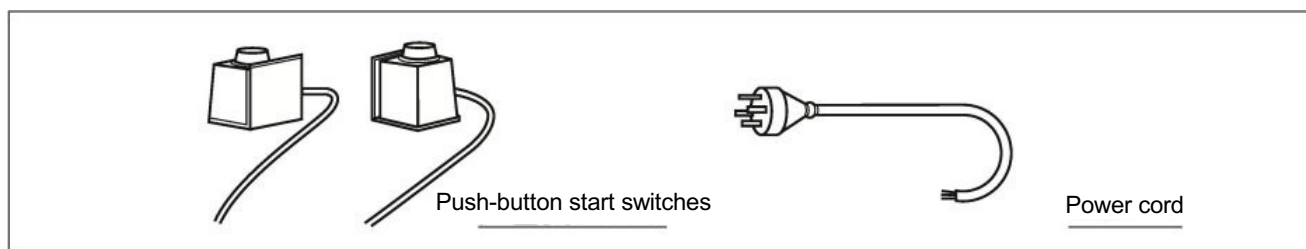

- Accessories for the head

The following accessories are included when you purchase the optional head and insert together with the machine.

- One hook pin wrench

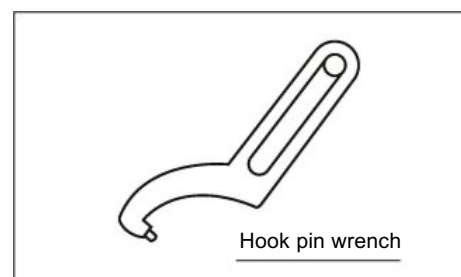



## ■ Standard head and optional insert

### Standard head

Standard heads and inserts compatible with the US-150 riveter are listed below.

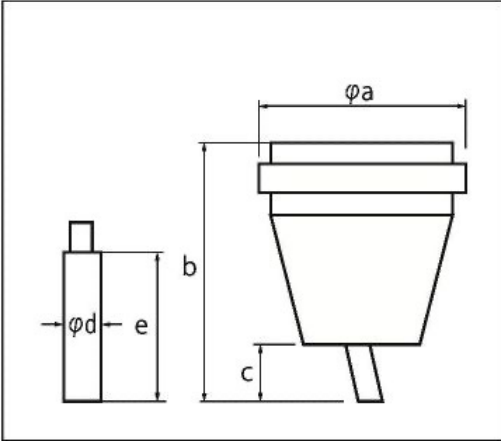

### ■ List of standard heads

( mm)

Head type	$\phi a$	b	c	$\phi d$	e
U-521	93	145	30	20	75
U-5214	93	169	54	20	100

- In addition to the standard heads, we have a variety of heads for different applications, so please contact us.

### Insert

The shape of the rivet tips can be broadly divided into the following 7 types. Basic dimensions such as the insert diameter and length are determined by the head. The rivet molding dimensions and materials must be specified in advance.

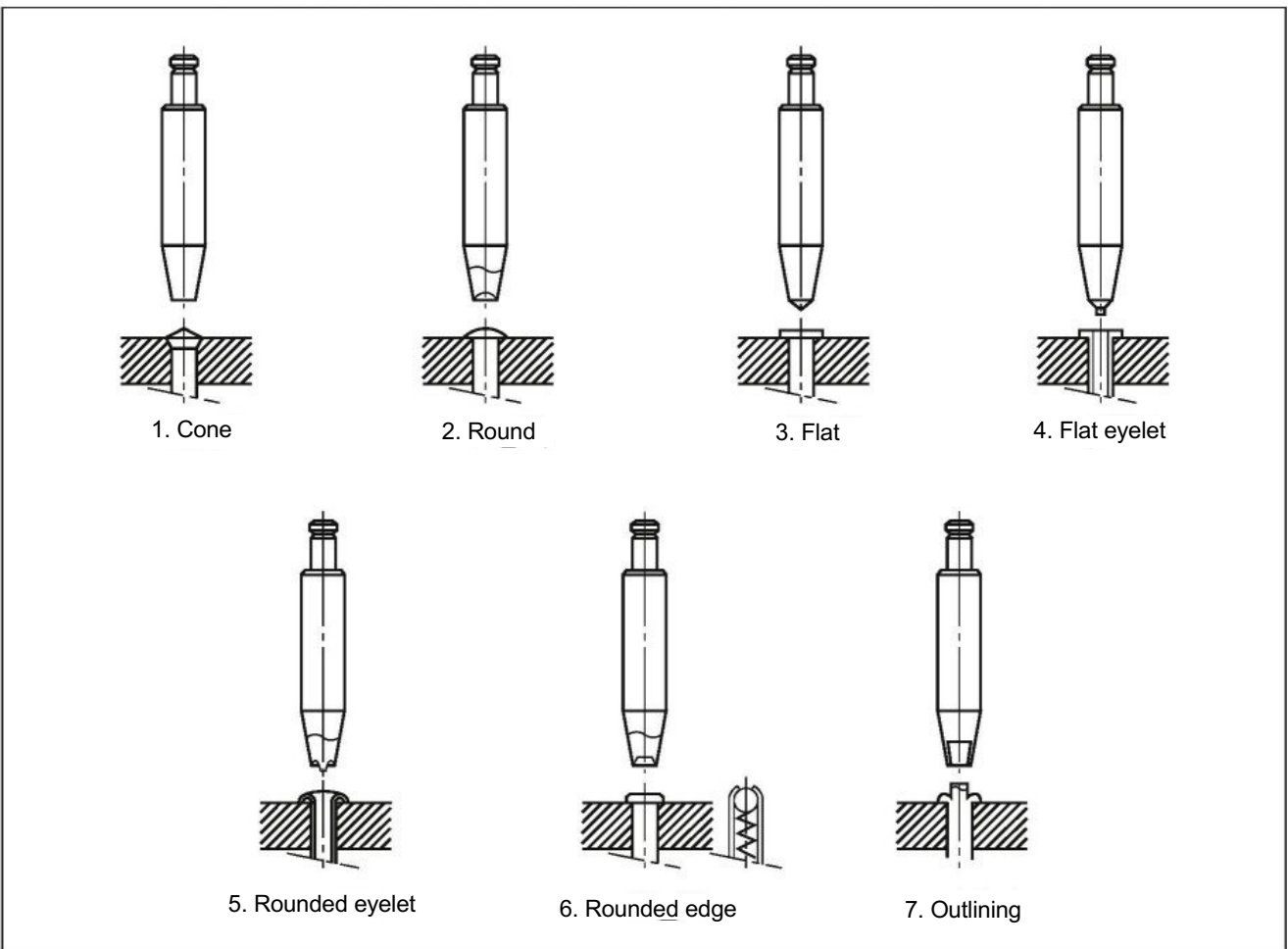

## ■ Jigs, tools and operation switches (optional)

In addition to the standard accessories, the riveter US-150 is available with optional accessories depending on your application.

### Jigs and tools

Name	Model names and specifications	Quantity
Anvil	ø48x40 (SKD-11)	1
Anvil base	Only for the US-150 (with washer)	1
Grease gun	With M6 nipple, grease pre-applied	1

### Operation switches

Name	Model names and specifications	Quantity
Emergency stop button	Mushroom push-return type	1
Foot switch *1	With a cover	1

\*1: Riveting work controlled by using a foot switch is very dangerous if operated incorrectly. Therefore, at the time of purchase, you need to fill in our request form to make sure you understand the need to instruct the user about secure environmental and work conditions that allow the machine to be used safely.



■ Name of each part

Fig.6

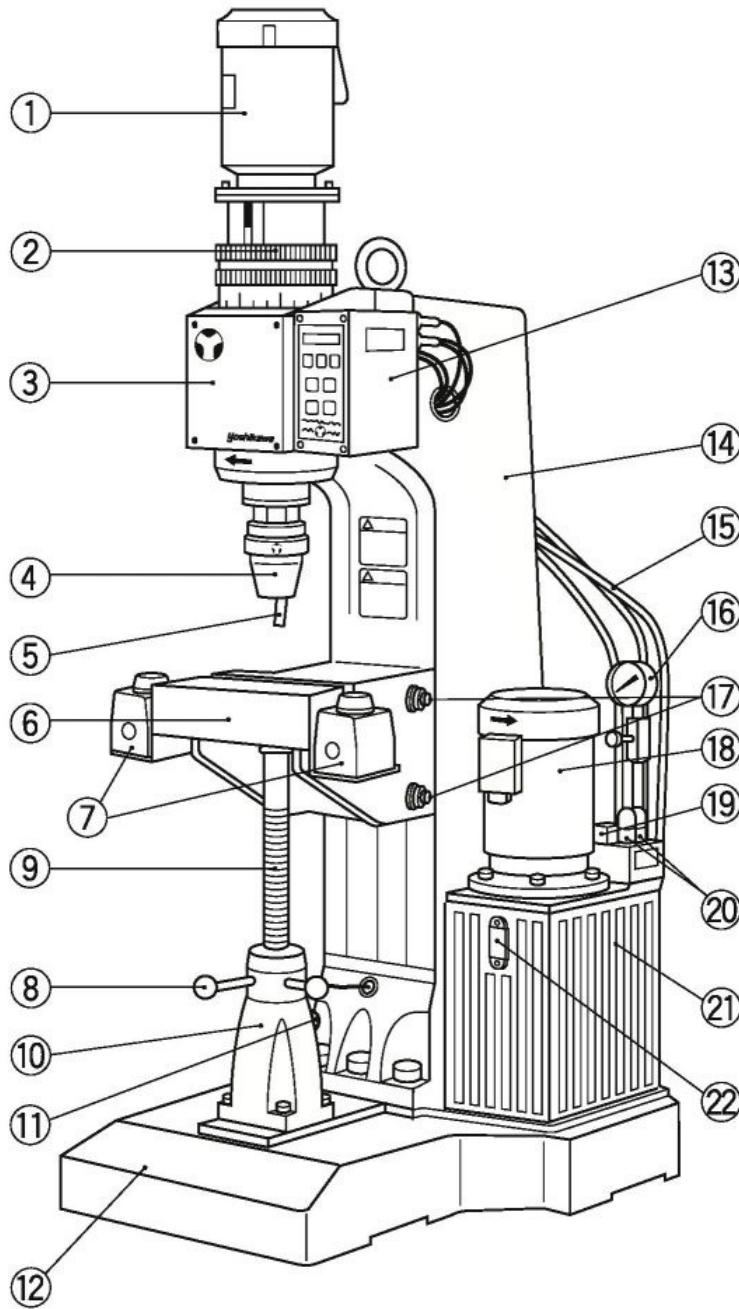

- ① Spindle motor
- ② Stroke adjust ring
- ③ Cylinder housing
- ④ Head (optional)
- ⑤ Insert (option)
- ⑥ Workpiece table
- ⑦ Double pushbutton switches
- ⑧ Handle for raising and lowering the table
- ⑨ Screws to set the table height
- ⑩ Stand for raising and lowering the table
- ⑪ Lock bolt
- ⑫ Bed
- ⑬ Controller
- ⑭ Column
- ⑮ Hydraulic hose
- ⑯ Pressure gauge
- ⑰ Hex nuts to secure the table
- ⑱ Hydraulic pump motor
- ⑲ Solenoid valve
- ⑳ Relief valve
- ㉑ Oil tank
- ㉒ Oil level gauge



## 2 Preparation for riveting

### 2-1 Workflow

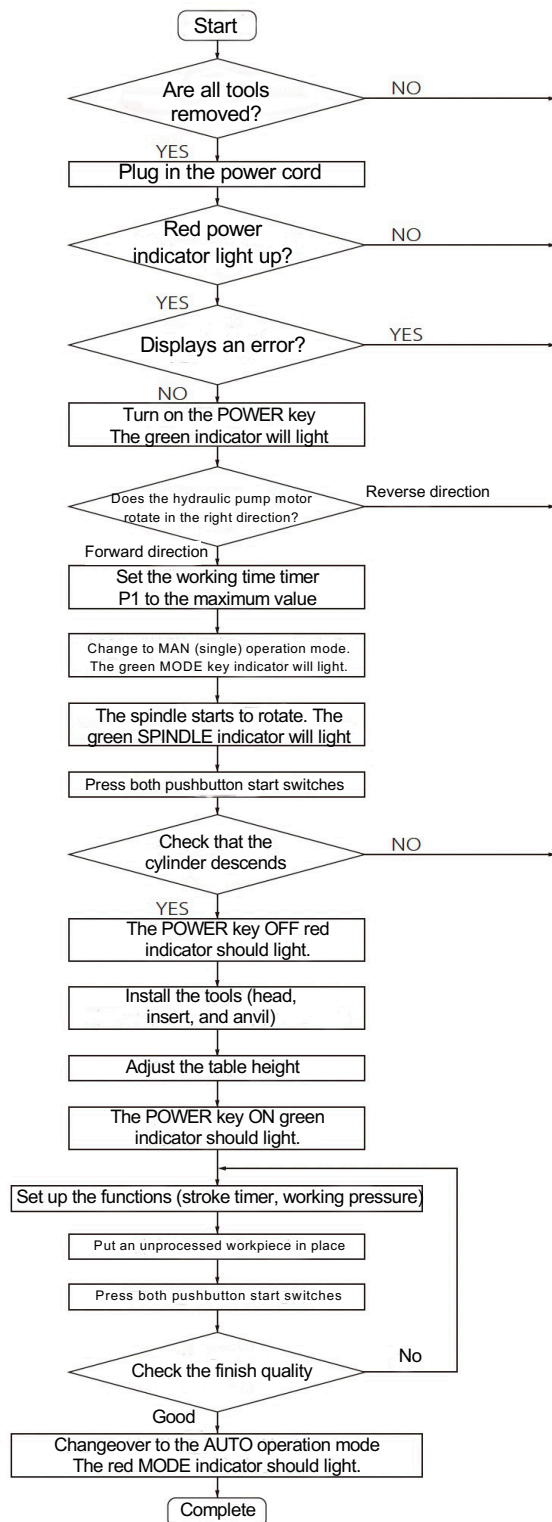

### CAUTION!

Before starting the operation, be sure to check the oil level in the hydraulic unit by looking at the oil level gauge

- ◆ Remove the tools (head, insert, and anvil) in advance, for safety.
- ◆ Unplug the power cord and check the primary power supply. Then, plug it in again..
- ◆ If "Err-\*\*\*" is displayed, press the  key to initialize the controller.
- ◆ After turning off the power, unplug the power cord and swap the wires for the two phases (red and black) in the plug.
- ◆ After turning off the power, unplug the power cord and check the connections for the start switches. Also check the function setting on the controller.



## 2-2 Connecting a power supply

The US-150 riveter is equipped with a 3-phase power cord plug, with a ground. Insert the plug into a three-phase AC 200V±10% 50/60HZ outlet on the primary side of the facility power supply.

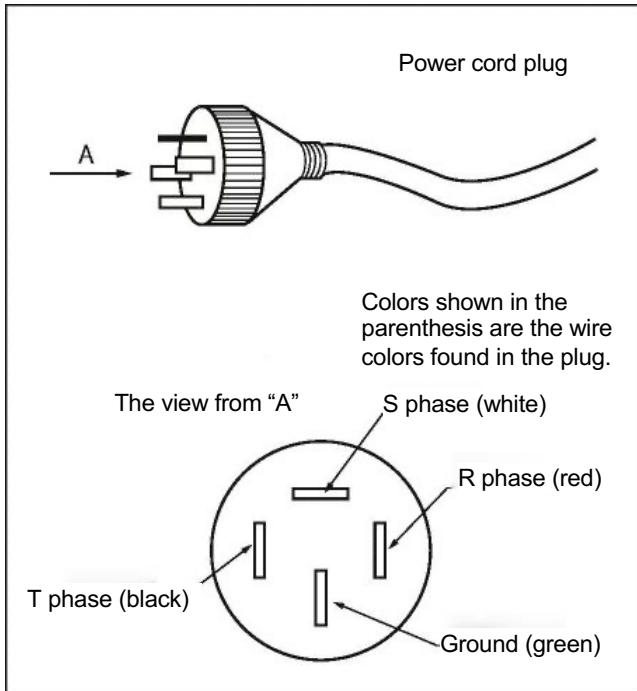

### WARNING!



Make sure the power cord plug is securely connected to ground. Otherwise, it may give someone an electric shock or cause a malfunction in the control equipment.

#### (1) Confirming the power supply

When the primary power is supplied, the  key's red OFF indicator will light. If it does not light, check the power supply.

#### (2) Error display

If [Err-\*\*] appears on the controller display when the power is turned on, press the  key. The memory will be initialized and the display will go blank.

The controller cannot be prepared for operation while an error is displayed. Be sure to reset the memory.

## 2-3 Turning the operation preparation step on and off

#### (1) Ready for operation

Press the  key on the control panel. The green power ON indicator will light, and the controller will enter the operation preparation step. Pressing the same key again, the OFF indicator light will light, and the operation preparation will stop.

#### (2) Confirm the motor rotation direction

The US-150 spindle motor and hydraulic tank motor are wired so that they will rotate in the appropriate direction when you plug in the power cord. However, if the phases of the primary power source are reversed, the motors will rotate in the reverse direction. In this case, the tools or the head may fall off or fly away from the machine, which can be very dangerous. After plugging the power cord in for the first time and BEFORE turning on the power, make sure to remove any tools and the head. Also, if the motors rotate in reverse direction, the hydraulic pump may be damaged. Therefore, stop the preparation for operation immediately and unplug the power cord. Then, swap the two-phase wires (red and black) inside the plug.

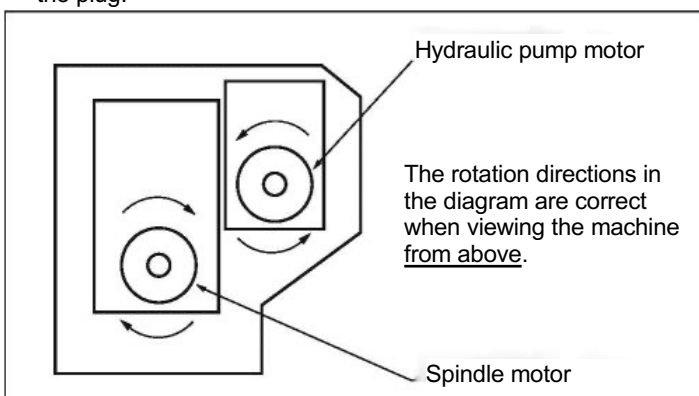

### DANGER!

- When connecting or disconnecting the power cord, hold the plug in your hands. Do not pull on the cord. Also, never put anything on the cord. It may cause a disconnection or short circuit.
- Do not put your fingers or other objects into the gap in the motor cover. It may cause a disconnection or short circuit.

## 2-4 How to install the riveting tools

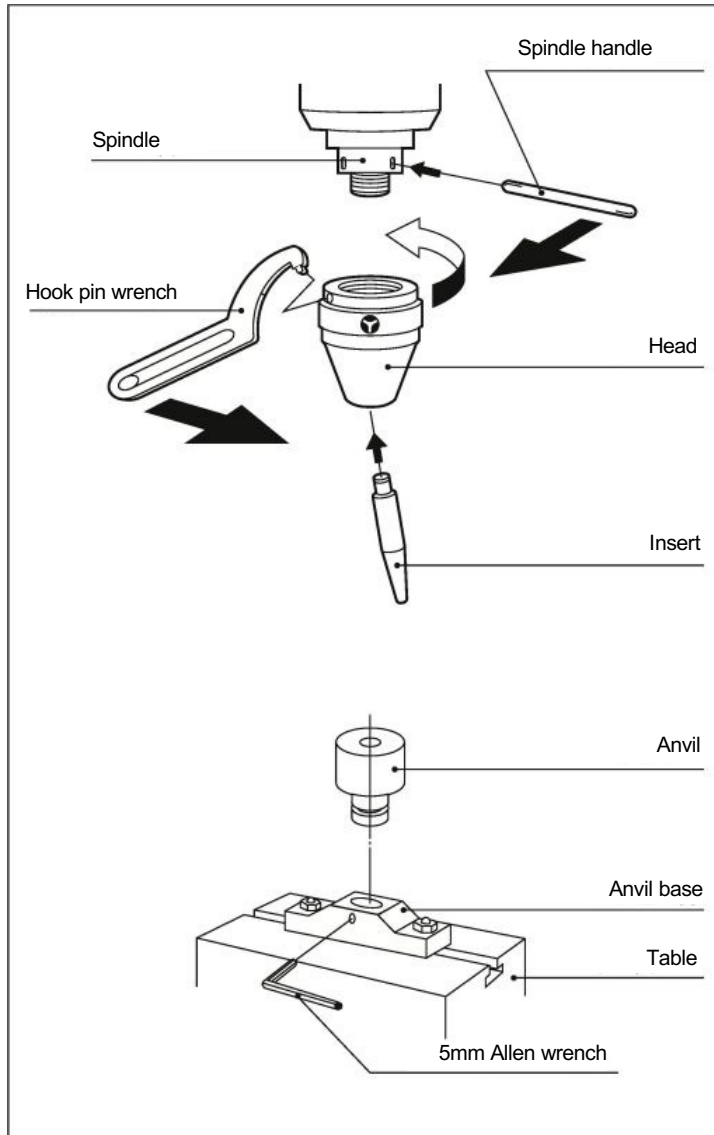

Set up the jigs and tools required for your riveting operation according to the following procedure.

### (1) Head (optional)

Screw the head onto the threads at the tip of the spindle. Insert the spindle handle into the spindle, as shown in the figure left. Insert the hook pin wrench into the hole on the side of the head and tighten the head with both hands.

### (2) Insert (optional)

Press the insert into the head, until it clicks into place.

### **⚠ CAUTION!**

- Make sure to install the head and inserts securely. If they are not installed correctly, they may fall off during operation.
- The insert may become very hot during riveting work. Therefore, wait for a while after the last operation for it to cool down, before removing the insert.
- If you touch the hot insert, you may be burned.

### (3) Anvil (optional)

Insert an anvil into the anvil base and tighten the set screw (M10) securely.

Use the optional T-type nuts to install a dedicated jig.

### **⚠ DANGER!**

Be sure to unplug the power cord before attaching jigs or tools to the riveting machine. Installing parts while the power is on is extremely dangerous. You may be seriously injured if the machine starts to operate.

### **⚠ CAUTION!**

The anvil and anvil base are optional items, like the head and insert, so you will need to center them the same way as when attaching a dedicated jig.

A special tool is required for centering. Please contact our sales office nearest to you if you need one.



## 3. Making adjustment

### 3-1 Stroke adjustment

#### Mechanical operation

There are three aspects of a riveting operation that have a very large influence on obtaining good results. They are: the Stroke, Pressing force and the Pressing time. Follow the procedure below to adjust each of these elements for proper riveting operation.

#### ⊘ CAUTION!

When adjusting the table height, turn the spindle motor switch off and check that the head has stopped moving before starting the adjustment.

Fig.7.1

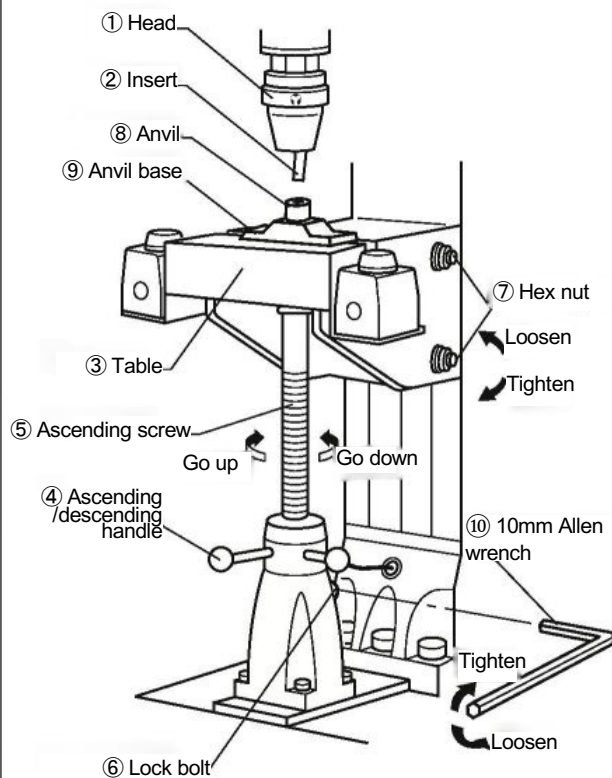

(1) Table height adjustment (see Fig.7.1)

a. Unclamping the table

Loosen the two hex nuts ⑦

b. Unlocking the ascending/descending screw

Loosen the lock bolt ⑥ on the screw stand using the 10mm Allen wrench.

c. Raise or lower the table

Turn the screw stand handle ④ to adjust the table height, so that workpieces can be removed from the gap between the anvil and insert tip, or the jig and the insert tip when the spindle is raised. However, if the gap is larger than cylinder stroke (45 mm), it will not be possible to perform riveting.

d. Securing the table

After determining the position of the table, tighten both hex nuts ⑦.

e. Securing the ascending/descending screw

To remove play in the ascending/descending screw ⑤, turn the ascending/descending handle ④ clockwise (as though lifting the table) to lock the screw position. Tighten the locking bolt ⑥ under the ascending/descending screw ⑤ using the 10mm Allen wrench.

That completes the table height adjustment. However, centering an optional anvil ⑧ and anvil base ⑨, or a dedicated jig with the head ① and insert ② must be done before adjusting the cylinder stroke.

Fig.7.2

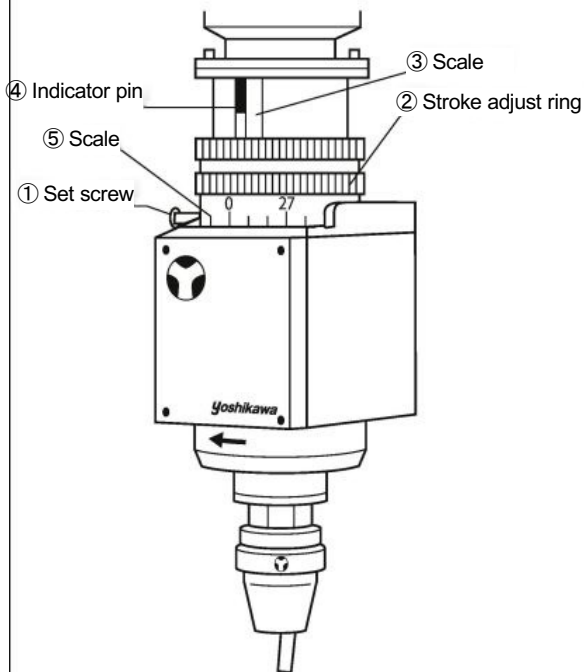

Scale

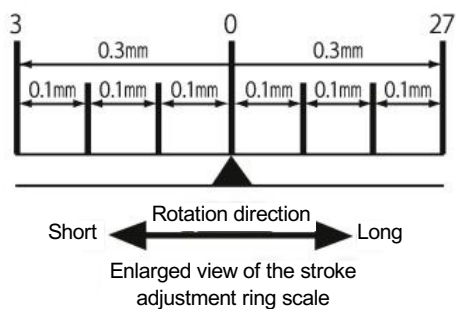
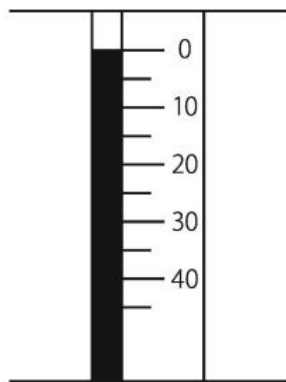

## (2) Cylinder stroke adjustment (see Fig.7.2)

### a. Unlocking the adjustment ring

Loosen the set screw ①.

### b. Stroke adjustment

Adjust the stroke by turning the stroke adjustment ring ② left and right. Turning the ring to the right will make the stroke longer and turning it to the left will shorten the stroke. One turn of the ring changes the stroke distance 3mm up or down. The stroke is displayed on the following two scales: The adjustment ring scale ③ displays 0 to 45mm. Look at the stroke indicator pin ④ to read the distance. 1 mark = 1 mm. Scale ⑤ shows the distance in 0.1 mm increments.

### c. Locking the adjustment ring

After adjusting the stroke, be sure to tighten the adjustment ring set screw, to secure it.

## (3) Precautions when adjusting the stroke!

Adjust the stroke starting from near 0 on the scale and then lengthen it gradually.

That is because, if a riveting operation is tried in the machine without a workpiece present, and it is set to a long stroke, any insert, anvil, or similar item may be damaged.

## 3-2 Adjusting the riveting pressure



**CAUTION!**

The source pressure relief valve ⑥ (red) has already been adjusted. Do not change it. If you use the machine at a pressure above the setting, it may damage the machine.

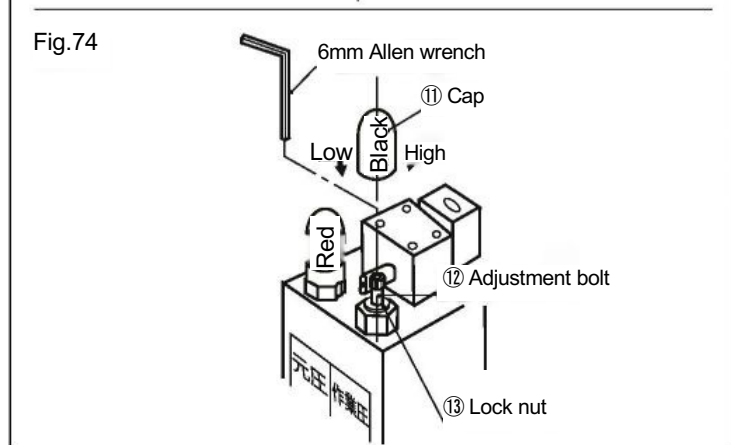
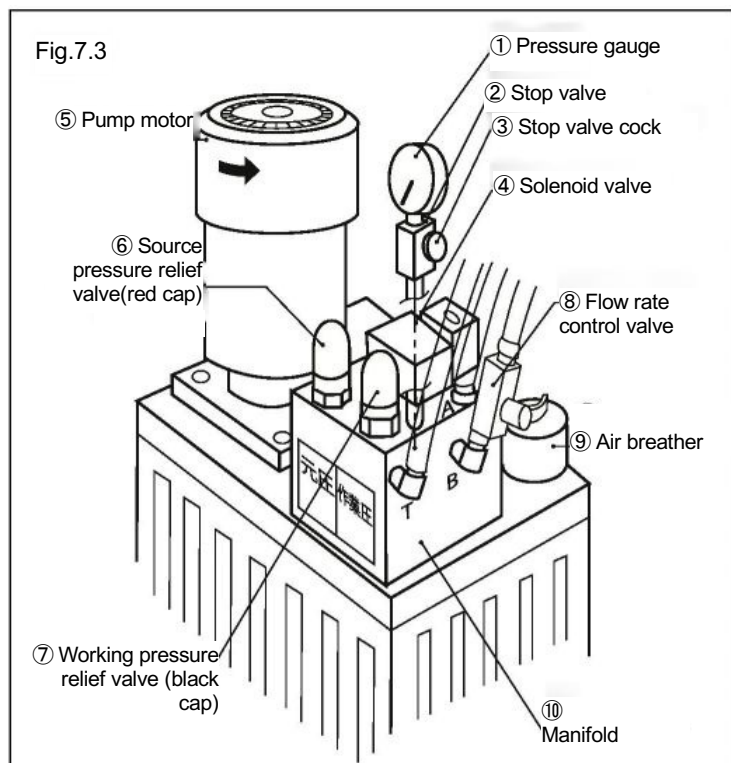

### b. Pressure setting

Adjust the pressure by turning the adjustment bolt using the supplied 6mm Allen wrench.

When seen from the end of the Allen wrench, turning it clockwise will increase the pressure, turning it counterclockwise will decrease the pressure.

### c. Precautions after adjusting the pressure

After adjusting the pressure, tighten the lock nut ⑬ and replace the cap ⑪. After adjusting the pressure, make sure to tighten the cock ③ on the stop valve ② while the pressure gauge needle points to 0 (no load).

The working pressure while riveting has a great effect on the finish of the workpieces to be processed and the processing time for the workpieces. Therefore, adjust the pressure as follows.

In addition, the power unit maximum pressure has been set by the source pressure relief valve (red), so that the pressure will not exceed the capacity of the machine.

[US-150: MAX pressure 12.25Mpa = 125kgf/cm<sup>2</sup>]

### (1) Preparation (see Fig.7.3)

#### a. Extending the pressurization time

In order to use the pressure gauge ① pointer, set a longer time for the work timer (P1). (approximately 9 seconds or longer).

#### b. Enable use of the pressure gauge

Loosen the stop valve cock ③ to activate the pressure gauge ①.

#### c. Preparing the work pressure relief valve (See Fig. 7.4)

Remove the black cap ⑪ on the work pressure relief valve ⑦ and loosen the lock nut ⑬ using a wrench (19).

To remove the cap, insert the tip of a flathead screwdriver into the recess and lift the cap up.

#### d. Flow rate adjustment

In order to increase the descent speed of the cylinder, turn the flow control valve knob all the way counterclockwise.

### (2) Pressure adjustment (see Fig.7.4)

#### a. Checking the working pressure

In order to check the current pressure setting, press the two start push buttons once, to lower the cylinder. Then read the pressure gauge. When operating without a workpiece, the pressure will be displayed on the pressure gauge after it reaches to the descent end.

## 3-3 Speed adjustment

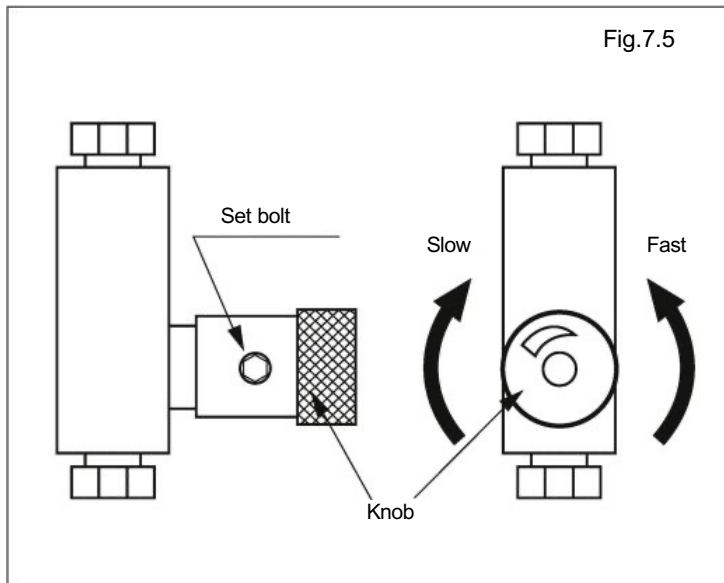

### (1) Adjusting the descent speed (Fig.7.5)

A flow control valve is installed to let you adjust the descent speed of the cylinder while riveting. Turn the knob clockwise to slow it down, turn it counterclockwise to speed it up.

Adjust the speed according to the workpieces to be processed.

After completing the adjustment, tighten the set bolt to lock the knob.

## 3-4 Work timer adjustment

The time required for processing by the riveting machine varies, depending on the material and shape of the rivets (workpieces), the cylinder stroke speed, and the pressure. Determine an appropriate work time by actually processing some workpieces.

For details about how to set the timer, see "3-2 Parameter Settings" in the Operating Instructions for the Riveting Controller YC-301.

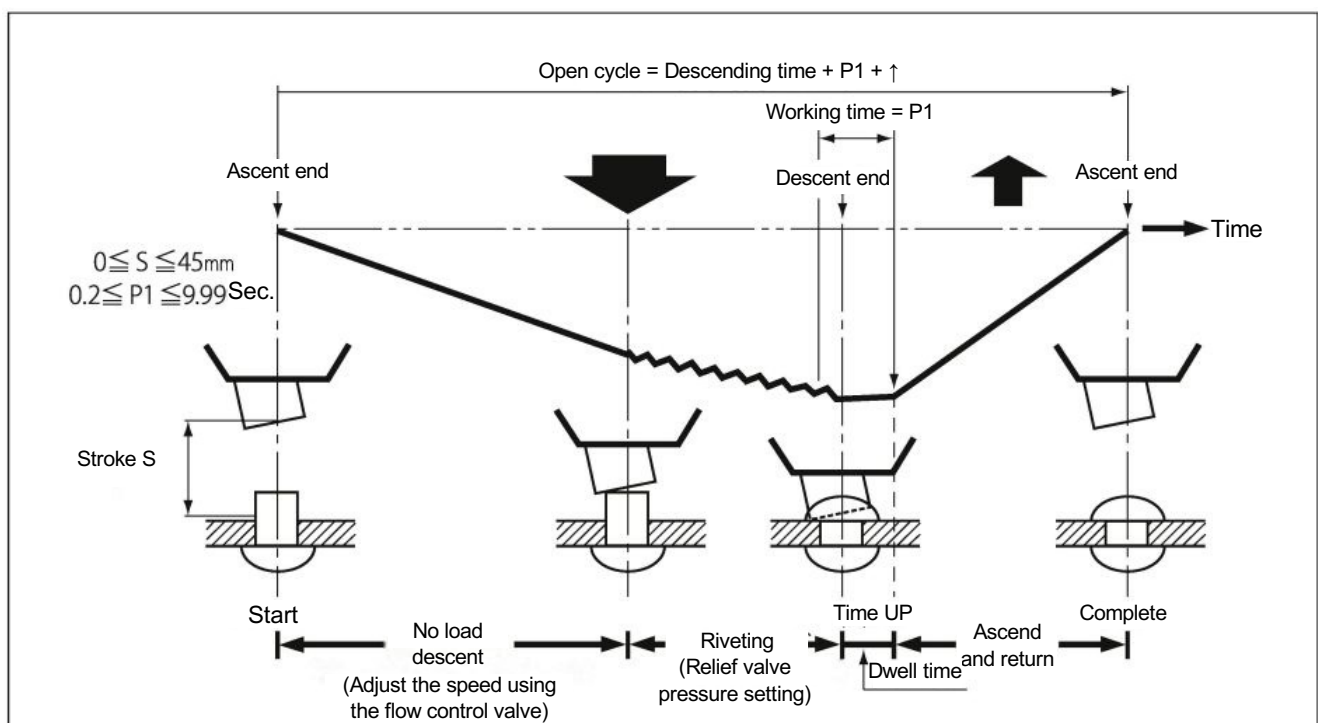



## ■ Head maintenance tasks

There is a bearing inside the head to receive the insert when it is installed. If the lubricating oil inside the head runs out or if the bearing wears out, the appropriate level of finish cannot be obtained.

In order to keep the finish routinely good, make sure to perform maintenance, such as lubricating, regularly.

### DANGER!

- During maintenance work, it is very dangerous if the machine were to start by mistake. Make sure to unplug the power cord before starting maintenance.

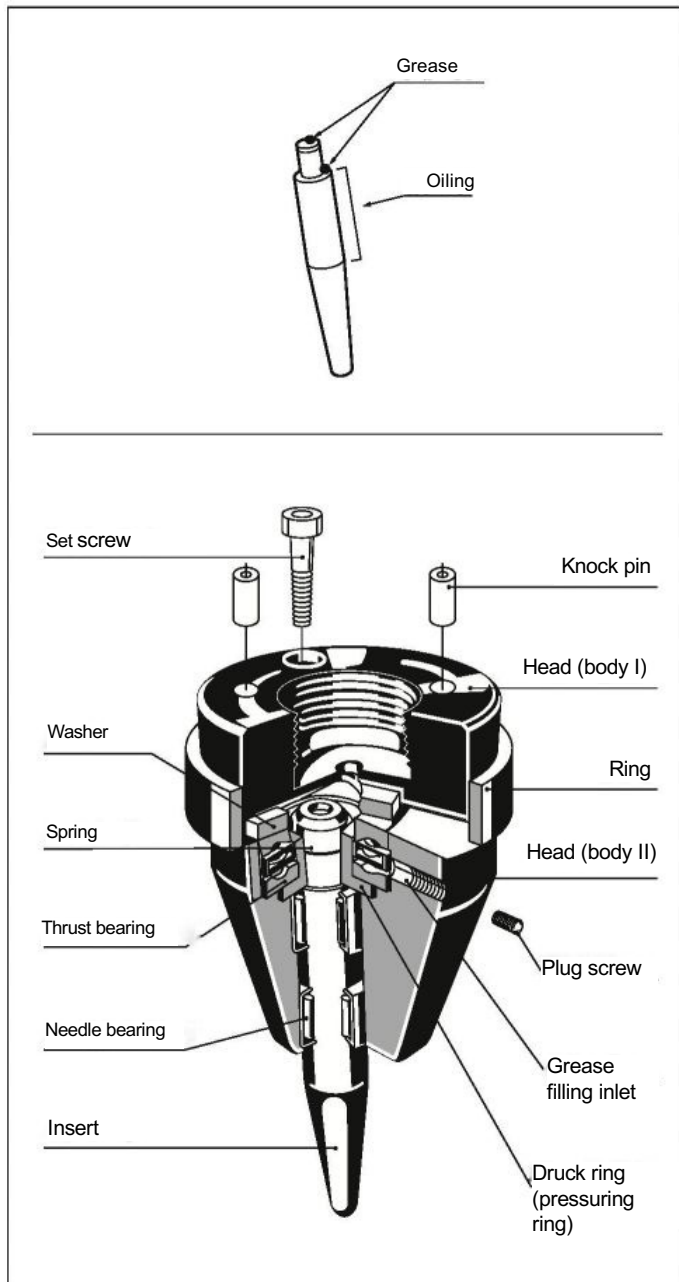

#### ◆ Refilling the lubricating oil

Lubricate the head once a week (approximately every 50 hours) as a guideline.

Use the grease listed below.

Grease: Lithium grease (Albania No. 2)

Apply a small amount (0.2cc) of grease to the tip of the insert. If too much is applied, the insert rotation will be poor, and the finish of the workpieces may be adversely affected.

#### ◆ About replacement parts

All parts used in the head are consumables. They should be replaced periodically depending on the head use conditions. In addition, genuine parts and special tools are required to replace parts, so please contact our sales office nearest to you.



## Machine maintenance tasks

In order to maintain good performance of the riveting machine for a long time, be sure to observe the following.

### DANGER!

- It is very dangerous if the machine starts running by mistake while performing maintenance work on the machine. Make sure to unplug the power cord before starting maintenance.

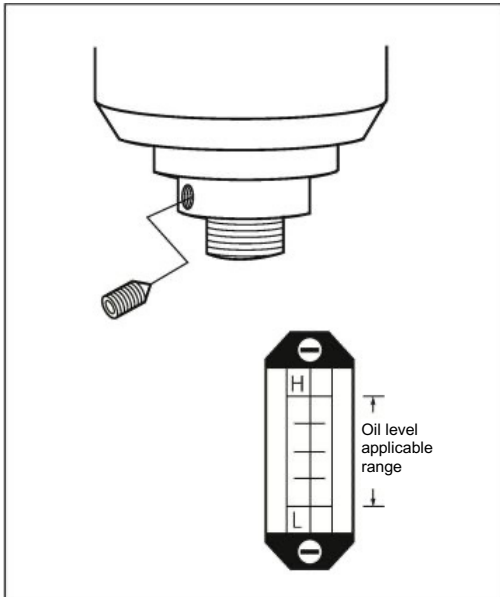

#### (1) Spindle lubrication

Depending on how often you use the machine, lubricate the spindle every 6 months (approx. 1,500 hours) as a guideline.

##### ◆ Lubrication procedure

As shown in the figure on the left, there is a lubrication port at the bottom of the spindle.

Remove the plug and screw in the tip of the grease gun.

The appropriate amount of lubrication is one trigger pull of the grease gun handle.

- Grease: Lithium-based grease (Albania No. 2)
- Grease gun: Our genuine product (optional)

#### (2) Replace the oil in the hydraulic unit

Replace the hydraulic oil once a year.

Also, check the oil level gauge before starting work to make sure that the amount of hydraulic oil is within the range shown in the figure on the left. If the level is below the "L" line, add hydraulic oil.

### DANGER!

- Never add oil near an open flame. Doing so could cause a fire.
- If the amount of oil decreases quickly, there is a possibility of an oil leak. That is dangerous. Stop using the machine immediately and contact us.

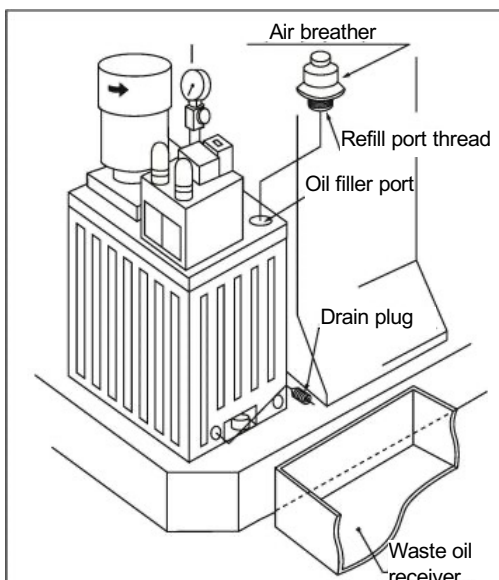

##### ◆ Replacement procedure

Prepare a container to receive the waste oil, remove the drain plug at the bottom of the tank, and drain all the hydraulic oil.

**Important:** Be sure to dispose of the drained oil as industrial waste.

- Tighten the drain plug, unscrew the oil refill port screw, add new hydraulic oil, and fill to the upper line on the oil level gauge.

(Before putting the drain plug back in, put Teflon tape on the plug threads and replace the rubber O-ring.)

- When full, tighten the refill port screw securely.

##### ◆ Recommended hydraulic oil

Turbine oil # 32 or equivalent

Tank capacity = 12L

Idemitsu: Daphne Super Hydro 32A

Showa Shell: Shell Terrace Oil 32

ENEOS: Super Hyrando 32



## ■ Daily checks

To maintain a good riveting finish and detect machine abnormalities early, make sure to perform the following inspections before starting work each day.

◆Work to be done before turning on the power		
Section to inspect	Inspection work	Precautions
Head	Rotate the insert with your finger, checking that it rotates smoothly.	If the rotation is difficult or the insert is stuck, clean the inside of the head. The bearing may have reached the end of its life.
Insert	Check that there is no powder from the riveting operations stuck on the tip of the insert.	If it cannot be wiped off with a cloth, etc., it will be necessary to reshape the tip. Never scrape the tip using a file or the like.
Hydraulic unit	Check if the oil level is appropriate by referring to the oil level gauge on the side of the tank.	If the amount of oil decreases quickly, there is a possibility of an oil leak and a repair is necessary.
◆Work to be done after turning on the power		
Working pressure	Open the stop valve, run a cycle without a workpiece. Check that the correct pressure is displayed on the pressure gauge.	Make sure there are no foreign objects between the insert and the anvil or insert and the jig before running the machine without workpieces.

Perform preventive maintenance during inspections, to ensure that the machine continues to operate properly for a long time.

Depending on the usage conditions, perform regular inspections every 6 to 12 months.

Maintenance and inspection work should be performed by technicians with specialized knowledge.

Make sure to shut off the primary power supply before performing periodic inspections.

If you have any problems or questions, please contact us as soon as possible.

- The terminal block screws must not be loose.
- There should be no dust or oil mist on the terminal block or inside the controller.
- Check that the controller mounting screws are not loose.
- There should be no damage to the wires or cables.
- The equipment must be undamaged.

## ■ Troubleshooting page

Machine problem	Causes		Countermeasures	
The preparation for operation step LED does not turn on.	Red POWER OFF LED indicator	Goes off	1. There is no primary power	Check facility's power supply
			2. The power cord is not plugged in.	Check the power cord
			3. The fuse is blown.	Replace the fuse
	Lights	1. An error appears on the display.	See the attached error display list *2	
2. Control equipment malfunction		Contact us		
Head does not rotate	1. Spindle switch is off.		Switch it on.	
	2. Operating on a single-phase power supply		Provide a three-phase power supply	
	3. Motor failure or broken joint in the cylinder		Replace or repair	
Cylinder does not rise when the power is turned on	1. Pressure setting is too low		Adjust the pressure	
	2. The pump motor is rotating backwards.		Swap the phase wires of the three-phase power cable in the plug	
	3. Operating on a single-phase power supply		Provide a three-phase power supply	
Riveting cylinder does not descend	1. Working pressure is set too low		Adjust the pressure	
	2. The flow control valve is closed.		Adjust the speed	
	3. Stroke is set to 0		Adjust the stroke	
	4. Working timer is set too short		Set the work timer	
	5. Defective solenoid valve		Replace or repair	
	6. Defective relief valve		Replace or repair	
	7. Low oil in the hydraulic unit		Refill with oil	
	8. Hydraulic pump failure		Replace or repair	
	9. Seal failure in cylinder		Replace or repair	
Head stops rotating when riveting	1. Defective bearing inside the head		Replace or repair	
	2. Defective spindle bearing		Replace or repair	
	3. Operating on a single-phase power supply		Provide a three-phase power supply	
Poor riveting				
The finish quality is not stable	1. Loose stroke adjustment screw and/or table clamp		Check the lock screw nut	
	2. The anvil or jig does not match the rivet shape.		Review jigs, etc.	
Burrs are seen	1. Cylinder stroke is too long		Adjust the stroke	
	2. The shape of the insert tip is not appropriate.		Check the insert	
	3. The rivets are not sufficiently tight		Check if the rivets are appropriate for the machine's settings.	
	4. The riveting center is misaligned.		Center all the devices	
The head of the rivet is torn or damaged.	1. There is metal powder on the insert tip.		Clean and/or repair the tip	
	2. Too much grease in the head		Clean and then apply the appropriate amount of grease	
	3. Defective bearing inside the head		Check and replace the bearing if necessary	
Not caulked	1. Low working pressure		Increase the working pressure	
	2. Defective bearing inside the head		Check and replace the bearing if necessary	
	3. Rivet spins with the insert or head		Improve the anvil and/or jig	
	4. Rivet material is too hard		Insufficient machine capacity	

◆For details about making adjustments, refer to the corresponding item in this manual.

\*2: Please check "3-2 Error display list" in the Operating Instructions for the "Riveting controller YC301".



## ■ Cylinder cross section

Part numbers inside a circle are consumables and need to be replaced periodically.

For inquiries about replacement work and replacement parts, please contact our sales office nearest you.

**CAUTION!**

Do not disassemble or modify the cylinder as it may cause an accident or a malfunction.

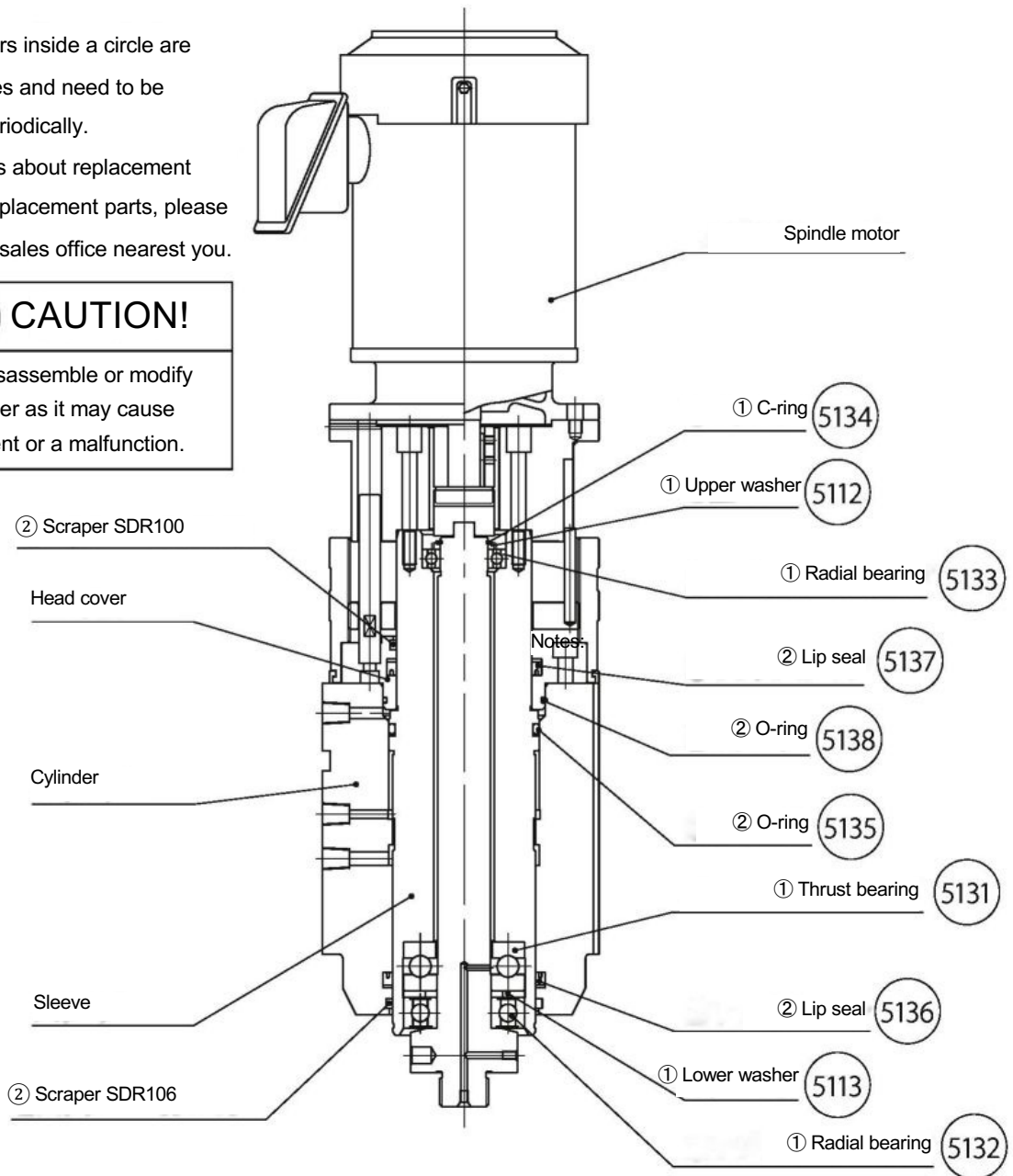

\* Parts ① and ② below must be replaced as a set.

① Bearing maintenance kit			
Part number	Name	Types	Quantity
5112	Upper washer		1
5113	Lower washer		1
5131	Thrust bearing	51408 (Special)	1
5132	Radial bearing	6308DDU	1
5133	Radial bearing	6007DDU	1
5134	C-ring for shaft	5-35	1

② Seal maintenance kit			
Part number	Name	Types	Quantity
5135	O-Ring	With P-102B	1
5136	Lip seal	SKY-106F, with B	1
5137	Lip seal	SKY-100F, with B	1
5138	O-Ring	6-115	1
—	Scraper	SDR-106	1
—	Scraper	SDR-100	1

■ Hydraulic circuit diagram

(Fig.8)

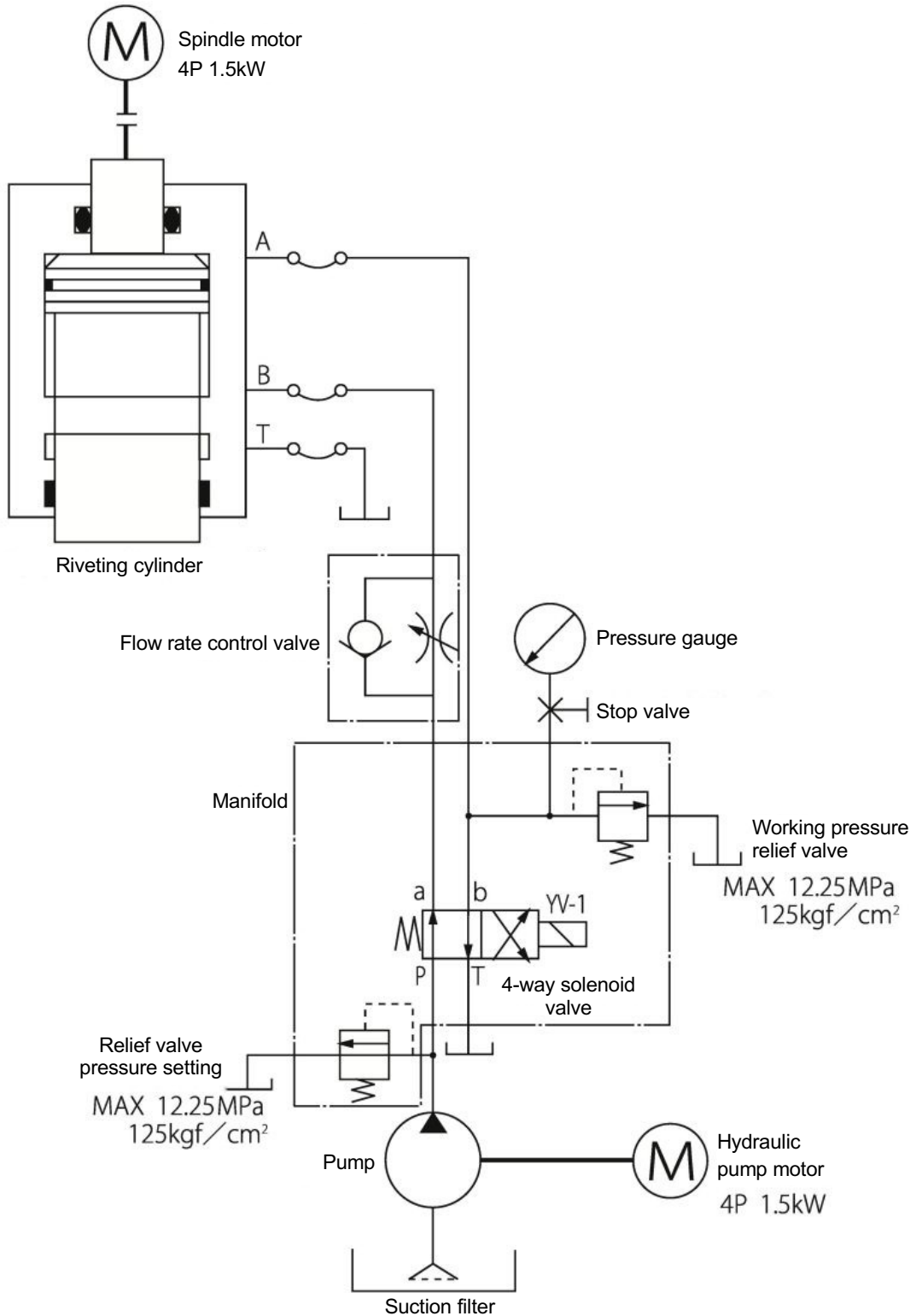



## ■ Thrust vs operating pressure diagram

(Fig.9)

Pressure curve chart

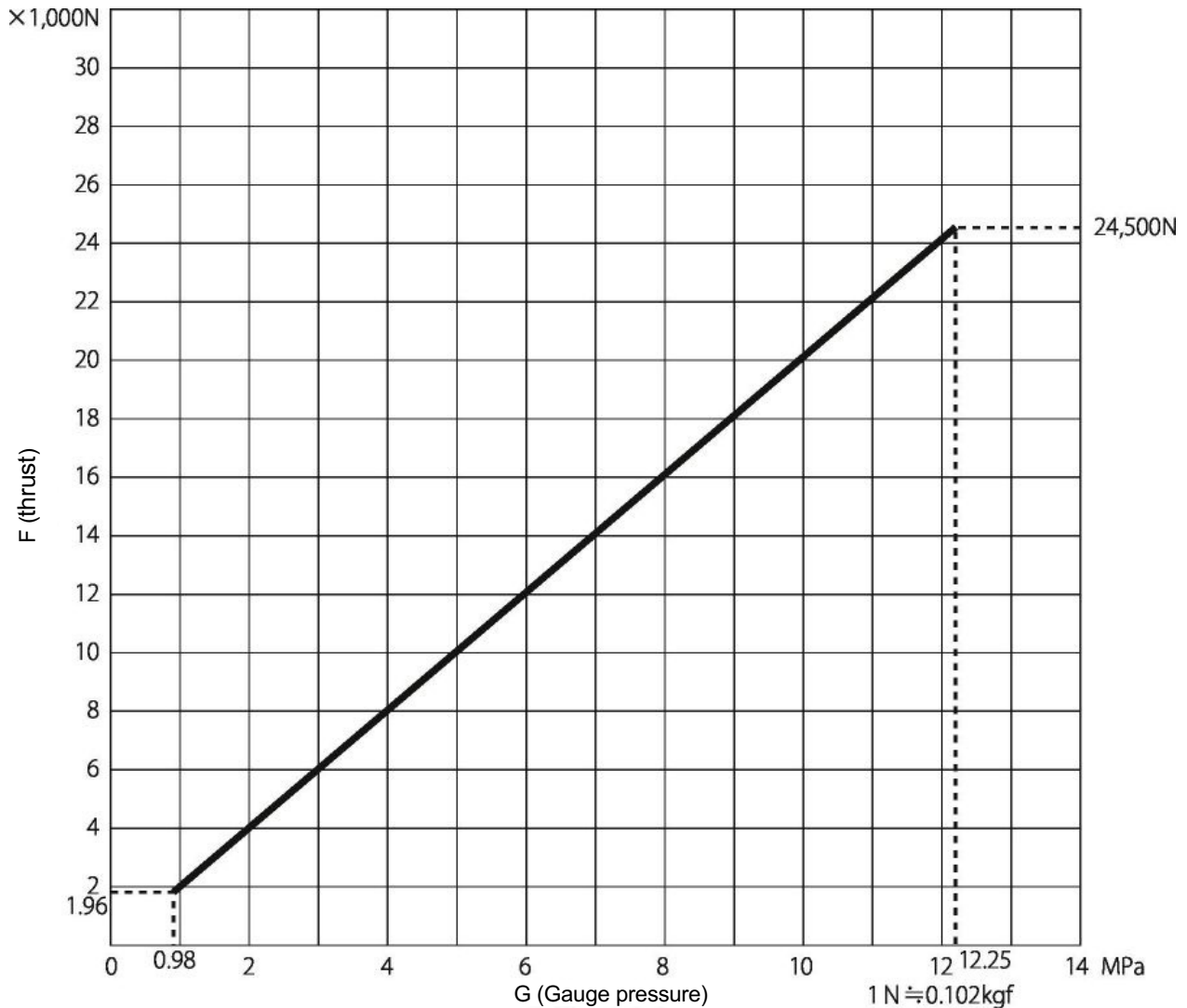

The graph above shows theoretical values based on the following formula. Use this as a reference when considering the riveting pressure.

$$F (\text{thrust}) = 20\text{cm}^2 \times G(\text{gauge pressure})$$

Unit: x1,000N

Table of thrust data, by rivet material

Rivet diameter mm \ Material	6	7	8	9	10	12	14	15	18	20
Mild steel	6	8	10	12	15	20	23	24.5		
Stainless steel	8	12	15	18	20	24.5				
Brass	6	6	7	9	10	12	14	18	22	24.5

Remarks: The above data is for reference to the condition of the insert shape = flat type, rivet = solid, and caulking margin = rivet diameter x 1/3. The actual working pressure will need to be adjusted each time.

■ Memo



## YOSHIKAWA IRON WORKS CO., LTD.

Headquarters & workshop: 3-7, Shitomiya Honmachi, Shijonawate City, Osaka  
TEL: (072)876-5151 FAX: 072-878-3329

Tokyo Sales Office: 4-12, 4 Chome, Okudo, Katsushika Ward, Tokyo  
TEL: (03)3694-1631 FAX: 03-3696-6090

Nagoya Sales Office: 1806, 1 Chome Takenoyama, Nisshin City, Aichi  
TEL: (0561)75-6660~5 FAX: 0561-74-2332

---